

# Resilmount A48R

Resilient Mount Right Angle Bracket



## APPLICATION

Resilmount A48R is an engineered, acoustic resilient mounting bracket for reducing airborne vibration and structure-borne vibration in internal wall and ceiling applications.



## FEATURES

- Unique, patented sound cell design to break up and absorb airborne sound.
- Engineered thermoplastic rubber outperforms standard rubber because of its sound absorbing characteristics.
- A48R is perfect for decoupling wall systems.
- A48R can be used to decouple almost anything from garage door motors to lockers.
- Resilmount is the most cost effective way to isolate airborne noise.
- Strong 'column' design provides minimal contact area with substrate whilst maintaining maximum structural integrity.
- Provided with several 3/16" slotted holes in bracket surface, suitable for direct fastening applications.
- 1/4" hole for most common fittings like 3/16" suspension rod.



## DYNAMIC CHARACTERISTICS

The Resilmount A48R right angle bracket can be mounted in several different orientations for a variety of acoustic-sensitive installations. All Resilmount products are precision manufactured by Studco Building Systems for complete control over the quality of each individual mount, in order to meet or exceed the architectural specifications required of each resilient mount. The patented Resilmount rubber insert has been independently tested and approved for use in the USA.

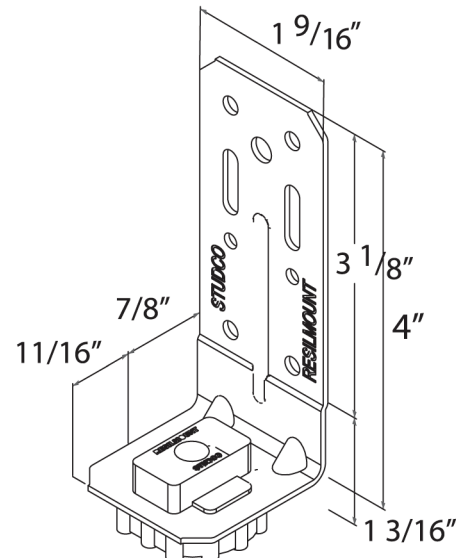

\*Uncontrolled copy. This document is subject to change without notice - please check currency of document prior to use.

WILREP LTD.

**AcoustiGuard™**  
SOUND & VIBRATION CONTROL

For Technical Support & Assistance,  
Contact AcoustiGuard - WILREP LTD. 1-888-625-8944

# Resilmount A48R



DataSheet



## INSTALLATION NOTES

- A48R to be fastened to structure with a minimum #8 screw or masonry sleeve anchors. (See fasteners manufacturers specifications).
- When using in ceiling applications, always check load ratings with Resilmount's engineers prior to installation.
- Do not over tighten wall fasteners.
- Must have a A-300 washer in fire rated assemblies.

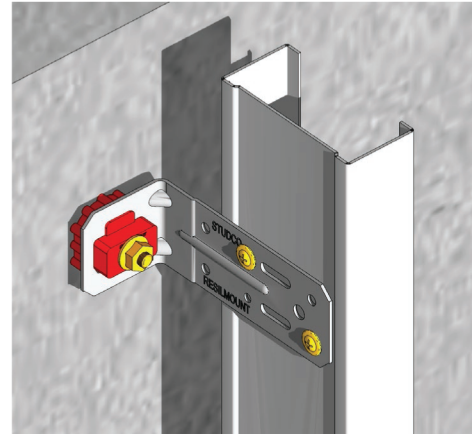

## SPECIFICATIONS

Code	Bracket Height	Weight Capacity (lbs)
A48R	4 3/8"	48

# Lead time and minimum quantities may apply.



## RELATED PRODUCTS

- A96R Resilmount Sound Isolation Clip w/bracket
- A237R Resilmount Isolation Clip
- A106R Resilmount Mounting bracket
- A24R Double Resilmount bracket



## WARRANTY

This product is covered by a year guarantee. Conditions and limitations of guarantees and warranties are set out in Studco Project Guarantee certificate.



## FURTHER ASSISTANCE

Contact the technical sales team at AcustiGuard - WILREP LTD. for assistance with specification, and product selection. Tel. 1-888-625-8944 or email [info@wilrep.com](mailto:info@wilrep.com)



## ACCREDITATION/CERTIFICATION

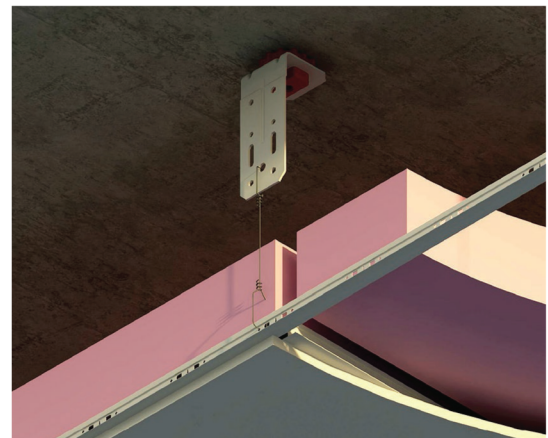
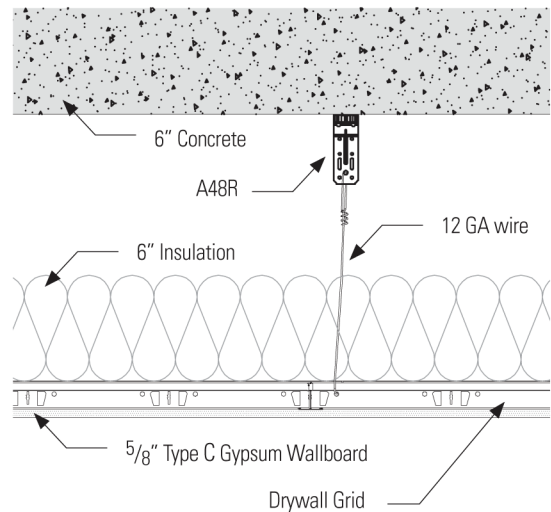

WILREP LTD.



For Technical Support & Assistance,  
 Contact AcustiGuard - WILREP LTD. 1-888-625-8944